

KGHA5801PSW

**HIGH ALTITUDE PRESSURE SWITCH KIT
FOR 2-STAGE AND VARIABLE SPEED
33.3-IN. (846 MM) TALL, MULTIPOISE
NON-CONDENSING FURNACES**

Installation Instructions

NOTE: Read the entire instruction manual before starting the installation.

SAFETY CONSIDERATIONS

Improper installation, adjustment, alteration, service, maintenance, or use can cause explosion, fire, electrical shock, or other conditions which may cause death, personal injury, or property damage. Consult a qualified installer, service agency, or your distributor or branch for information or assistance. The qualified installer or agency must use factory-authorized kits or accessories when modifying this product. Refer to the individual instructions packaged with the kits or accessories when installing.

Follow all safety codes. Wear safety glasses, protective clothing, and work gloves. Have a fire extinguisher available. Read these instructions thoroughly and follow all warnings or cautions include in literature and attached to the unit. Consult local building codes, the current editions of the National Fuel Gas Code (NFGC) NFPA 54/ANSI Z223.1 and the National Electrical Code (NEC) NFPA 70.

In Canada, refer to the current editions of the National Standards of Canada CAN/CSA-B149.1 and .2 Natural Gas and Propane Installation Codes, and Canadian Electrical Code CSA C22.1.

Recognize safety information. This is the safety-alert symbol . When you see this symbol on the unit and in instructions or manuals, be alert to the potential for personal injury.

Understand the signal words **DANGER**, **WARNING**, and **CAUTION**. These words are used with the safety-alert symbol. **DANGER** identifies the most serious hazards which **will** result in severe personal injury or death. **WARNING** signifies hazards which **could** result in personal injury or death. **CAUTION** is used to identify unsafe practices which **may** result in minor personal injury or product and property damage. **NOTE** is used to highlight suggestions which **will** result in enhanced installation, reliability, or operation.

WARNING

FIRE, EXPLOSION, ELECTRICAL SHOCK HAZARD

Failure to follow this warning could result in personal injury, death and / or property damage.

Improper installation, adjustment, alteration, service, maintenance, or use can cause carbon monoxide poisoning, explosion, fire, electrical shock, other conditions, which could result in personal injury or death. Consult your distributor or branch for information or assistance. The qualified installer or agency must use only factory-authorized kits or accessories when servicing this product.

WARNING

FIRE, EXPLOSION, ELECTRICAL SHOCK HAZARD

Failure to follow this warning could result in personal injury, death, and / or property damage.

Before installing or servicing unit, always turn off main electrical and gas to unit and tag with appropriate lockout. There may be more than one disconnect switch.

CAUTION

CUT HAZARD

Failure to follow this caution may result in personal injury.

Sheet metal parts may have sharp edges or burrs. Use care and wear appropriate protective clothing, safety glasses and gloves when handling parts and servicing furnaces.

WARNING

FIRE, EXPLOSION, ELECTRICAL SHOCK HAZARD

Failure to follow this warning could result in personal injury, death and / or property damage.

The ability to properly perform service on this equipment requires certain expertise, mechanical skills, tools, and equipment. If you do not possess these, do not attempt to perform any service on this equipment other than those procedures recommended in the User's Manual.

INTRODUCTION

This instruction covers the installation of high-altitude pressure switch kit KGHA5801PSW in the two-stage and variable-speed, 80% AFUE, 33.3-in. (846 mm) induced-combustion furnaces. The switch set points are shown on the label attached to the front of the switch. For high-altitude installations, the high-altitude conversion kit **MUST** be installed at or above 5,500 ft. (1676 M) above sea level.

KIT CONTENTS

The high-altitude pressure switch kit contains the following items:

Description	Quantity
High Altitude Switch Assy.	1
Installation Instructions	1

Table 1 – Models

58CTA	58CVA	312AAV	880TA	PG8MVA
58CTX	58CVX	312JAV	881TA	PG8JVA
58CTW	58TN	314AAV	820TA	PG8JVB
58CTY	58TP	314JAV	821TA	PG80VTL
		315AAV		
		315JAV		

DESCRIPTION AND USAGE

This high-altitude pressure switch kit is required for the installation of the two-stage and variable-speed, 80% AFUE, 33.3-in. (846 mm) induced-combustion furnaces for high altitude installation (above 5,500 ft. [1676 M] above sea level) for the furnaces shown in Table 1. The switch set points are shown on the label attached to the front of the switch.

Step 1 — Installation of Pressure Switch Assembly

1. Mark two (2) wires connected to the high-fire pressure switch.
2. Disconnect the two (2) wires from the high-fire pressure switch.

3. Remove screw securing switch assembly to casing.
4. Disconnect the bypass tube from the high-fire pressure switch.
5. Remove the two (2) screws securing high-fire pressure switch to mounting bracket. (See Fig 1).
6. Remove existing high-fire pressure switch from the mounting bracket.
7. Install new high altitude high-fire pressure switch to the mounting bracket with two (2) screws.
8. Connect the bypass tube to the high altitude high-fire switch.

NOTE: Replacement switch is shipped with a new bypass tube. Remove and discard if existing tube is not cracked or torn.

9. Install switch assembly to casing using screw.
10. Reconnect wires to the switch as shown in Fig. 1 or refer to the furnace wiring diagram.
11. Check furnace for proper operation (refer to furnace Installation Instructions).

Step 2 — Derating Input

The gas inputs on rating plate are for altitudes up to 2000 ft. (610 M) above sea level. Ratings for altitudes over 2000 ft. (610 M) must be 4 percent less for each 1000 ft. (305 M) above sea level.

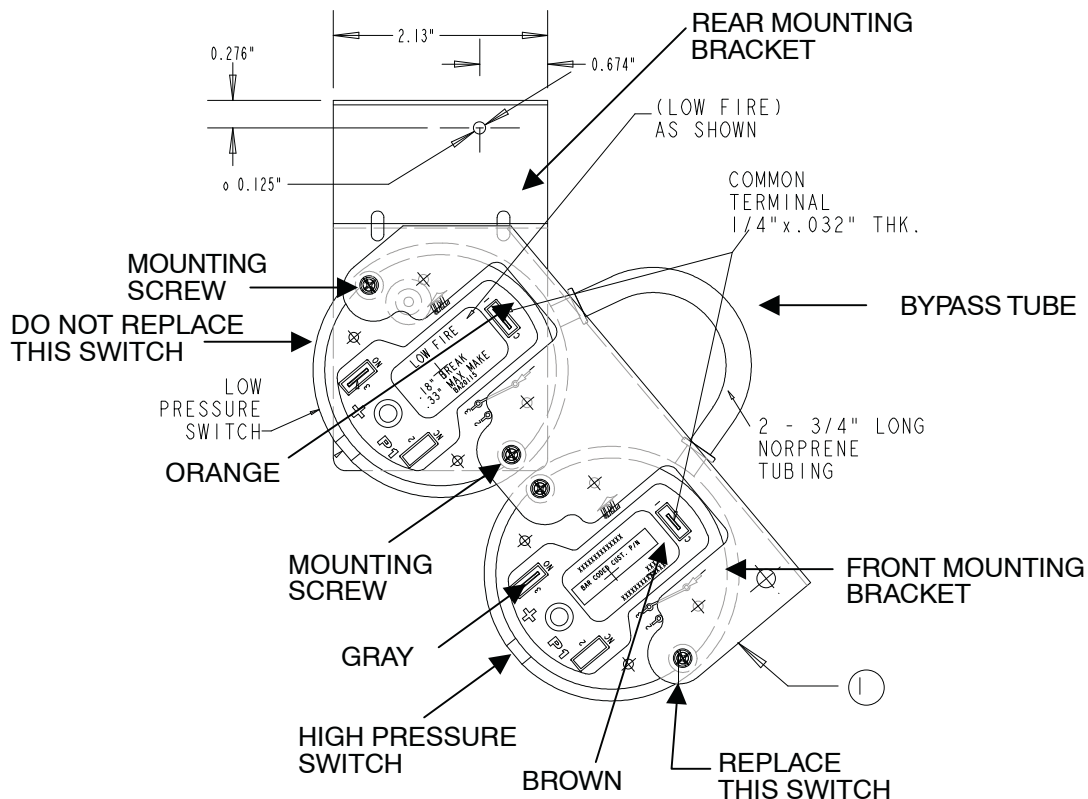

Fig. 1 - Pressure Switch
Note: Bracket appearance may vary.

A02243