

326627–751 thru
326627–764

Replacement Inducer Housing Kit For Use With 33–1/3 in. Non–Condensing Gas Furnaces

Installation Instructions

NOTE: Read the entire instruction manual before starting the installation.

SAFETY CONSIDERATIONS

Improper installation, adjustment, alteration, service, maintenance, or use can cause explosion, fire, electrical shock, or other conditions which may cause death, personal injury, or property damage. Consult a qualified installer, service agency, or your distributor or branch for information or assistance. The qualified installer or agency must use factor-authorized kits or accessories when modifying this product. Refer to the individual instructions packaged with the kits or accessories when installing.

Follow all safety codes. Wear safety glasses, protective clothing, and work gloves. Have a fire extinguisher available. Read these instructions thoroughly and follow all warnings or cautions include in literature and attached to the unit. Consult local building codes, the current editions of the National Fuel Gas Code (NFGC) NFPA 54/ANSI Z223.1 and the National Electrical Code (NEC) NFPA 70.

In Canada, refer to the current editions of the National Standards of Canada CAN/CSA-B149.1 and .2 Natural Gas and Propane Installation Codes, and Canadian Electrical Code CSA C22.1

Recognize safety information. This is the safety-alert symbol . When you see this symbol on the unit and in instructions or manuals, be alert to the potential for personal injury.

Understand the signal words **DANGER**, **WARNING**, and **CAUTION**. These words are used with the safety-alert symbol. **DANGER** identifies the most serious hazards which **will** result in severe personal injury or death. **WARNING** signifies hazards which **could** result in personal injury or death. **CAUTION** is used to identify unsafe practices which **may** result in minor personal injury or product and property damage. **NOTE** is used to highlight suggestions which **will** result in enhanced installation, reliability, or operation.

Follow all safety codes. Wear safety glasses and work gloves. Have a fire extinguisher available.

WARNING

FIRE, EXPLOSION, ELECTRICAL SHOCK AND CARBON MONOXIDE POISONING HAZARD

Failure to follow instructions could result in personal injury, death or property damage.

Improper installation, adjustment, alteration, service, maintenance, or use can cause carbon monoxide poisoning, explosion, fire, electrical shock, or other conditions, which could result in personal injury or death. Consult your distributor or branch for information or assistance. The qualified installer or agency must use only factory-authorized kits or accessories when servicing this product.

INTRODUCTION

This instruction covers the inducer housing installation on mid-efficiency hot surface igniter units. The inducer housing

should be replaced when corrosion has created visible surface damage to the box, damage to the pressure switch pressure tap or anytime functionality of the inducer housing has been compromised.

NOTE: It is very important that you verify that the inducer housing you are installing is the same size as you are removing. Always verify the flue restrictor HOLE SIZE before installing an inducer housing.

DESCRIPTION AND USAGE

The inducer housing replacement kit can be utilized to restore units having inducer housings that require repair. This kit contains the following items: inducer housing, inducer housing screws, inducer motor mounting screws, vent elbow screws, inducer motor gasket and installation instructions.

INSTALLATION

NOTE: The low adhesion sealant used on the Replacement Inducer Housing Kit is Novaguard RTV 400-900 (Part Number PF680004).

If the high adhesion sealant is used, also use a releasing agent such as cooking spray (must not contain corn oil, canola oil, halogenated hydrocarbons nor aromatic contents to prevent inadequate seal from occurring). Novaguard 400-303 RTV (Part Number PF680003), G.E. 162, G.E. 6702, or Dow-Corning 738 are approved high adhesion silicone.

DO NOT substitute any other type of RTV sealant.

NOTE: It may be helpful to remove the burner box assembly from furnaces with narrow cabinets to facilitate removal of inducer housing. To remove the burner assembly, follow the steps below. If the inducer housing is readily accessible, proceed to Step 2.

Step 1 — Remove the Burner Assembly

1. Turn off electric supplies to unit and set thermostat to lowest setting or “OFF”. More than 1 disconnect may be required to disconnect power to unit.

WARNING

ELECTRICAL SHOCK HAZARD

Failure to follow this warning could result in personal injury or death.

Before installing or servicing system, always turn off main power to system and tag disconnect switch with a suitable warning label. There may be more than one disconnect switch.

2. Remove exterior door.
3. Turn off gas at external supply shut-off and turn electric switch on gas valve to “OFF”.
4. Disconnect wires from gas valve.
5. Disconnect main limit switch wires from main limit switch on cell panel.
6. Disconnect wires from roll-out switches located at the ends of the burner box.
7. Remove wiring harness stand-off from top edge of burner box.

8. Disconnect HSI harness from HSI.
9. Disconnect flame sensor wire from flame sensor.
10. Disconnect gas line at external union or pipe connection.
11. Remove the green/yellow ground wire attached to the manifold mounting tab, re-install screw.
12. Support the burner assembly while removing the 4 screws that attach the burner assembly to the cell panel.

NOTE: The hot surface igniter is extremely fragile. Failure to support the burner assembly could result in damage to the hot surface ignition.

13. Remove the burner assembly and set aside to prevent damage.

Step 2 — Remove the Inducer Housing

1. Turn off electric supplies to unit and set thermostat to lowest setting or “OFF”. More than 1 disconnect may be required to disconnect power to unit.
2. Remove exterior door by loosening thumbscrew and pulling door forward.
3. Turn off gas at external supply shut-off and turn electric switch on gas valve to “OFF”. On models with a gas control knob, turn knob to “OFF”.

 **CAUTION**

PERSONAL INJURY HAZARD

Failure to follow this caution may result in personal injury.

Vent connector may be hot to the touch or have sharp edges. Gloves should be worn when handling sheet metal parts.

4. Disconnect and remove vent connector from vent elbow.

NOTE: Support vent connector with temporary metal strap to prevent damage to vent connector or vent connector elbows.

5. Disconnect draft safeguard switch leads from draft safeguard switch on vent elbow.
6. Remove vent elbow from inducer housing.
7. Unplug inducer motor wires from wiring harness.
8. Disconnect pressure switch tube from inducer housing.
9. Remove pressure switch bracket from furnace casing. It is not necessary to disconnect pressure switch wires.
10. Remove screws from top corners of furnace casing (upflow furnaces only).

NOTE: Verify the orientation of the motor wiring harness and inducer cooling shield before removing inducer motor assembly. Inducer motor assembly must be re-installed in same orientation for proper furnace operation.

11. Remove 3 screws securing inducer assembly (motor, wheel, and mount) to inducer housing and remove inducer motor assembly. Note where inducer motor ground lead is connected.

 **CAUTION**

PERSONAL INJURY HAZARD

Failure to follow this caution may result in unit damage.

Failure to support the inducer assembly during removal may damage the inducer wheel.

12. Remove screws securing inducer housing to front of cell panel.
13. Use putty knife or automotive-type gasket scraper to carefully pry up on inducer housing assembly where it meets cell panel. Start at the bottom corner and work knife or scraper along inducer housing to break silicone seal. Continue to pry around inducer housing until inducer housing can be removed.

14. Clean any remaining silicone residue from cell panel with a wire brush, scraper or fine steel wool.

Step 3 — Installation of Inducer Housing

NOTE: The low adhesion sealant used on the Replacement Inducer Housing Kit is Novaguard RTV 400-900 (Part Number PF680004).

If the high adhesion sealant is used, also use a releasing agent such as cooking spray (must not contain corn oil, canola oil, halogenated hydrocarbons nor aromatic contents to prevent inadequate seal from occurring). Novaguard 400-303 RTV (Part Number PF680003), G.E. 162, G.E. 6702, or Dow-Corning 738 are approved high adhesion silicone.

DO NOT substitute any other type of RTV sealant.

1. Spray face surface of cell panel with a releasing agent.
2. Apply 3/16-in. to 1/4-in. bead of high temperature silicone around the back outside edge of inducer housing.
On 2 cell models: Measure in 4 inches and apply a vertical bead down the back of the inducer housing (See Fig. 1).

NOTE: Do not allow RTV to flow into pressure switch port. Pressure switch will not operate with port obstructed.

3. Realign inducer housing assembly against cell panel and install all screws.
4. Verify old inducer motor gasket is removed from inducer assembly and inducer housing.
5. Place new inducer motor gasket provided in kit around flange on inducer housing (See Fig. 2).

NOTE: A new inducer assembly gasket is provided in the inducer housing kit.

6. Align inducer assembly and attach to inducer housing. Verify inducer motor is oriented correctly and ground wire is reinstalled in original location.
7. Spin black plastic cooling fan on inducer motor to be certain there is no interference inside of inducer housing. If interference occurs, wheel must be readjusted.
8. Re-install screws in top corners of furnace casing.
9. Reinstall pressure switch bracket.

NOTE: Verify pressure switch port on inducer housing plate is not obstructed by inserting a small wire or drill bit into the port. If wire has RTV on it when it is removed, it may be necessary to remove inducer housing, clean pressure switch port area and re-attach inducer housing as explained above.

10. Connect pressure switch tubing to inducer housing fitting.
11. Re-install vent elbow to inducer housing.
12. Re-attach vent connector to vent elbow.
13. Re-connect inducer motor leads to inducer motor and draft safeguard leads to draft safeguard switch.

Step 4 — Installation of Burner Assembly

NOTE: If burner assembly was not removed, proceed to Step 5.

NOTE: The hot surface igniter is **extremely** fragile. Failure to support the burner assembly could result in damage to the hot surface ignition.

1. Align burner box with mounting holes in cell panel and re-install the 4 mounting screws.
2. Remove the screw from the manifold mounting tab and re-attach the green/yellow ground wire attached to the manifold.

NOTE: Failure to properly ground burner assembly will result in loss of flame sensing signal.

3. Connect flame sensor wire from flame sensor.
4. Connect HSI harness to HSI.
5. Connect leads to main limit on cell panel.
6. Connect leads to rollout switches on burner box.
7. Attach wiring harness standoff(s) to top edge of burner box.

⚠ WARNING

ELECTRICAL OPERATION HAZARD

Failure to follow this warning could result in personal injury or death.

Failure to attach wiring harness standoff(s) may result in damage to the safety circuit wiring.

8. Connect leads to gas valve. Refer to wiring diagram for correct orientation.
9. Connect gas line at external union or pipe connection.
10. Turn on gas at gas supply shut-off and gas control (knob or switch).
11. Leak test gas connections with soap and water solution or electronic leak detection equipment suitable for use with natural and propane gases.

⚠ WARNING

FIRE OR EXPLOSION HAZARD

Failure to follow this warning could result in personal injury, death, and/or property damage.

Never purge a gas line into a combustion chamber. Never test for gas leaks with an open flame. Use a commercially available soap solution made specifically for the detection of leaks to check all connections. A fire or explosion may result causing property damage, personal injury or loss of life.

12. Turn on line voltage electrical supply.

NOTE: Blower will run for 90 sec if thermostat is set to call for heat when 120-v power is restored. A status code 12 will flash after 90 sec. To clear the status code, turn off power, turn thermostat "OFF" or down below room setting. Turn power back on. Set thermostat to desired temperature.

Step 5 — System Check-Out

1. Set thermostat to "OFF". Initiate component test through circuit board by referring to "Component Test" on status code label on blower access door for complete test sequence information.

2. If any status codes are flashed, refer to status code label on unit blower door.
3. Set thermostat to call for heat.
4. Allow unit to initiate a complete call for heat cycle.
5. Check for air leakage around inducer housing. A whistling noise may indicate air leak in inducer housing seal.

NOTE: If there is a severe air leak in the inducer housing seal, pressure switch may not close or will re-open, resulting in no ignition or erratic burner operation.

NOTE: Corrosion at the inducer housing may have been caused by one or more of the following conditions. As part of the system check-out, verify that the following conditions are not affecting the operation of the furnace:

- **Short Cycling-Defective thermostat:** Incorrect thermostat anticipator setting, dirty filter or over-sized furnace.
- **Under firing/low BTU input:** Set manifold pressure and verify firing rate as shown on rating plate by clocking the gas meter.
- **Low temperature rise:** Set unit for correct temperature rise range as shown on unit rating plate.
- **Contaminated combustion air:** Remove contaminants or provide ample fresh air for combustion.
- **Excessive amounts of outside ventilation air:** Return air temperature cannot be below 60 degrees F for extended periods of time.
- **Incorrect venting:** Verify proper venting per local code. Type B vent connector is required for 2 stage units and may be required for other applications.

For additional information, and a complete sequence of furnace operation, refer to furnace Installation, Start-Up and Operating Instructions.

6. After System Check-out is complete, set thermostat below room temperature.
7. Verify that burner shuts down and blower completes selected off delay furnace time.
8. Verify furnace operates properly and set thermostat to desired room temperature.
9. Re-install outer door.

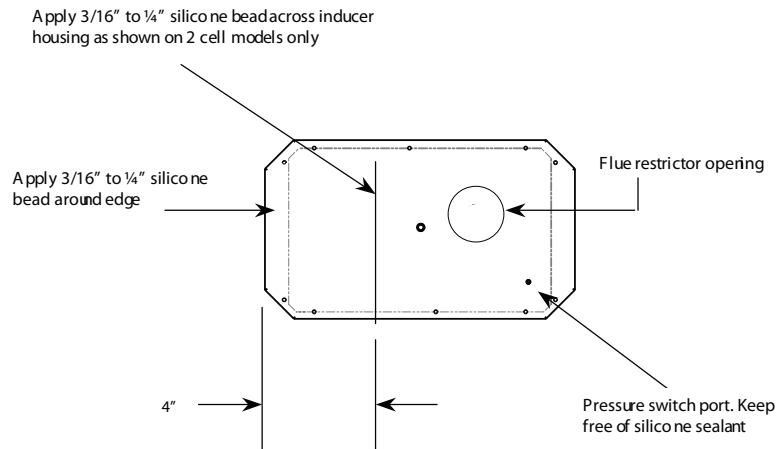

Fig. 1 - Inducer Housing

A10238

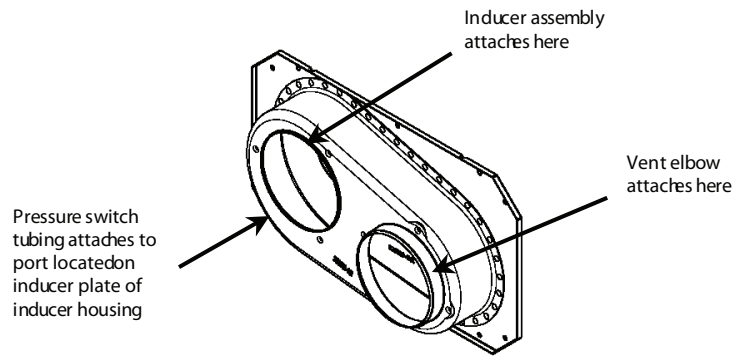

Fig. 2 - Front View of Inducer Housing

A10239