

Blower Housing Replacement Kit

Cancels: New

IJK-310A-45-9

6/02

Installation Instructions

Part No. 327265-751 thru 327265-753

Part No. 327266-751 and 327266-753

NOTE: Read the entire instruction manual before starting the installation.

SAFETY CONSIDERATIONS

Installing and servicing heating equipment can be hazardous due to gas and electrical components. Only trained personnel should install or service heating equipment.

Untrained personnel can perform basic maintenance functions such as cleaning coils, or cleaning and replacing filters. All other operations should be performed by trained service personnel. When working on heating equipment, observe precautions in the literature, on tags, and on labels attached to the unit. Recognize safety information. This is the safety-alert symbol . When you see this symbol on the unit and in instructions or manuals, be alert to the potential for personal injury.

Understand the signal words DANGER, WARNING, and CAUTION. These words are used with the safety-alert symbol, . DANGER identifies the most serious hazards which **will** result in severe personal injury or death. WARNING signifies a hazard which **could** result in personal injury or death. CAUTION is used to identify unsafe practices which **would** result in minor personal injury or product and property damage. NOTE is used to highlight suggestions which **will** result in enhanced installation, reliability, or operation.

Follow all safety codes. Wear safety glasses and work gloves. Have a fire extinguisher available.

 **WARNING:** Improper installation, adjustment, alteration, service, maintenance, or use can cause carbon monoxide poisoning, explosion, fire, electrical shock, or other conditions which could result in personal injury or death. Consult your distributor or branch for information or assistance. The qualified installer or agency must use only factory-authorized kits or accessories when servicing this product. Failure to follow instructions could result in serious injury or property damage.

INTRODUCTION

This instruction covers the blower housing installation on non-condensing, 33.3 inch high, mid-efficiency hot surface ignitor units. The blower housing should be replaced when there is visible damage to the blower housing.

DESCRIPTION AND USAGE

The blower housing replacement kit can be utilized to restore units having blower assemblies that require repair. This kit contains the following items: Blower housing assembly with cut-off plate and a loose parts bag with screws.

A replacement motor and blower wheel are NOT included in this kit and must be ordered separately.

INSTALLATION

Step 1—Remove the Existing Blower Assembly

1. Turn off electric supplies to unit and thermostat. More than 1 disconnect may be required to disconnect power to unit.
2. Remove exterior door by loosening knurled knob on door and pulling forward.
3. Turn off gas at external supply shutoff and turn electric switch on gas valve to "OFF".



CAUTION: Vent connector may be hot to the touch or have sharp edges. Gloves should be worn when handling sheet metal parts. Failure to follow this warning could result in personal injury.

4. On downflow or horizontal positions where the vent connector passes in front of the blower access panel, disconnect and remove vent connector from vent elbow.

NOTE: Support vent connector with temporary metal strap to prevent damage to vent connector or vent connector elbows.

5. Remove the screws that secure the blower access door and set door aside.

6. Remove the screw that secures the blower door switch to the front edge of the heat exchanger cell panel
7. Remove the wiring harness from the recess in the blower shelf.
8. Remove the blower leads that connect the motor to the furnace control.



CAUTION: Mark wires prior to disassembly to aid re-assembly. Wiring errors could result in improper or dangerous operation

Note: Pull motor leads out by the connectors to prevent damage to the relay terminal on top of the control board or pulling the wire out of the connector.

- 9a. On some Variable Speed furnace models, disconnect the wires from the power choke and remove the power choke mounted to the blower housing.
- 9b. On furnaces with PSC motors, remove the capacitor strap and capacitor from the blower assembly
10. Remove the 2 screws that secure the control box assembly to the blower shelf inside the blower compartment.
11. Move the control box aside. Secure control box assembly aside with a scrap length of wire or tape.
12. Using a 5/16 wrench or ¼" ratchet and 5/16" socket, remove the 2 blower housing mounting screws that secure the blower assembly to the blower shelf.
13. Slide the blower assembly forward, out of the blower compartment.

Step 2—Remove Blower Motor

1. Remove the 4 screws that secure the blower cut-off plate to the blower housing
2. Loosen the setscrew that attaches the blower wheel to the flat spot on the motor shaft.

Note: Mark the position of the motor mounting arm before disassembly. This will ensure that the motor is re-installed in the proper position.

3. Lay the blower assembly on its side and remove the 3 or 4 screws that secure the motor mounting arms to the blower housing.

4. Remove the green ground lead from the side of the blower housing. Note the location for re-assembly
5. Slide the motor out of the blower wheel hub.

Note: If the motor will not slide out of the wheel, perform the following steps:

6. Set the blower assembly, motor side down on a crate or wooden box with a generous amount of padding inside.
7. Apply a small amount of lubricant between the shaft of the motor and the hub of the blower wheel.

8. Tap the shaft of the motor using a block of wood, wooden dowel pin or a ¾" brass drift pin. **DO NOT HAMMER DIRECTLY ON THE SHAFT OF THE MOTOR.** The motor shaft may "mushroom" and prevent the motor from being removed from the wheel.

You may also use a commercially available tool that clamps on the blower wheel hub and pushed the motor out of the wheel. When the motor drops into the box or crate, remove it from the box and set it aside.

10. Remove blower wheel from housing



CAUTION: The blower wheel should not be dropped, as balance will be affected

11. Clean blower wheel and motor if necessary.

Step 3—Assemble the Blower

1. Remove the cut-off plate from the new blower housing.
2. Lay blower housing on its side and insert the wheel into the housing. Verify the blower wheel is in the correct position for proper rotation.
3. Insert blower motor shaft into hub of blower wheel.
4. Check to see the blower wheel is not jammed against the blower housing before installing motor mounting screws.
5. Align the motor mounting arms as marked during disassembly.
6. Install blower motor mounting screws in blower housing. Do not over-tighten.

7. Attach the green ground wire from the motor to the sheet metal of the blower housing.



WARNING: The furnace must be grounded to minimize personal injury if an electrical short should occur. Failure to follow this warning could result in personal injury of death.

8. Center the blower wheel in the opening of the blower housing. Align the set-screw on the flat portion of the blower shaft. Torque set screw in the range of 140 to 160 in./lbs

9. Install the blower cut-off in the blower housing.

IMPORTANT: The long screws provided in the kit go through the side of the housing. The short screws attach the cut-off plate through the wrapper of the blower housing (See Fig. 1 or 2).

Step 4—Install Blower Assembly in Furnace

1. Insert the flanges of the blower housing into the rail of the furnace blower deck

2. Slide the blower assembly into the furnace until it is fully seated in the blower compartment.

3. Install the 5/16" screws to blower deck in the furnace through the opening in the flange on the blower housing.

4. Tighten the screws with a 5/16" wrench or ¼" ratchet and 5/16" socket .

5a. On some Variable Speed furnace models, reinstall the power-choke to the blower housing.

5b. On furnaces with PSC motors, install the capacitor strap and capacitor to the blower housing.

6. Install the control box assembly to the front of the blower shelf of the furnace.

7a. Connect the electrical leads to the terminals on the control board. If wires were not marked during disassembly, refer to the wiring label on the blower access door.

7b. On ECM models, plug 5-pin and 16-pin connectors into the motor module. Both connectors are indexed for correct orientation.

8. Install the wiring harness in the recess of the blower shelf.

9. Secure the wiring harness by installing the blower door switch to the front edge of the heat exchanger cell panel. Use caution when installing the switch to prevent wires from being pinched.

10. Spin blower wheel by hand to verify that wheel does not rub against housing.

Step 5—System Check-Out

1. Set thermostat to "OFF". Manually close blower door switch. Initiate component test through circuit board by referring to "**Component Test**" on status code label on blower access door for complete test sequence information.

2. If any status codes are flashed, refer to status code label on unit blower door.

3. Release the blower door switch

4. Install blower access panel on furnace and secure with the 2 existing screws.

5. Turn thermostat fan switch to "ON", to initiate a call for continuous fan operation.

6. Verify that the blower wheel does not rub against the housing.

7. On Downflow or Horizontal models, install the vent connector if the connector was removed. Verify that no other connectors or joints were damaged during disassembly.

8. Turn gas ON at external shut off and at electric switch on gas valve.

9. Set thermostat to call for heat.

10. Allow unit to initiate a complete call for heat cycle.

NOTE: Blower wheel or motor failure may have been caused by one or more of the following conditions. As part of the system check-out, verify that the following conditions are not affecting the operation of the furnace:

- **High external static pressure:**
Dirty filter or high pressure drop filter.
Undersized filter grills. Restricted or undersized duct systems. Dirty evaporator coil.
- **Noise:** High air flow due to high external static pressure. Incorrect speed tap selected for heating temperature rise or cooling airflow
- **Vibration:** Unit not set flat or level. Blower wheel bent or out of balance. Flexible duct connectors not used with sheet metal ducts

For additional information, and a complete sequence of furnace operation, refer to furnace Installation, Start-Up and Operating Instructions.

5. After System Check-out is complete, set thermostat below room temperature

6. Verify that burner shuts down and blower completes selected off delay furnace time.

7. Verify furnace operates properly and set thermostat to desired room temperature.

8. Release the blower door switch.

9. Install the blower access door

10. Re-install outer door.

Fig. 1-Expanded View of PSC Blower Assembly

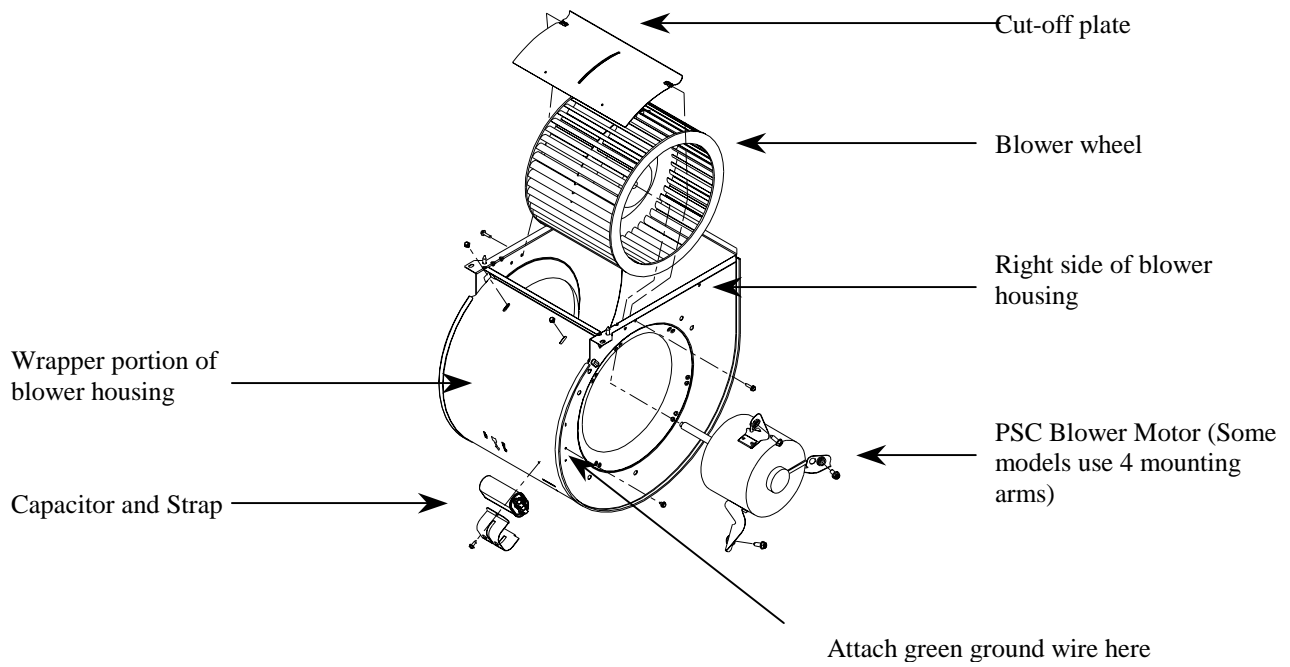
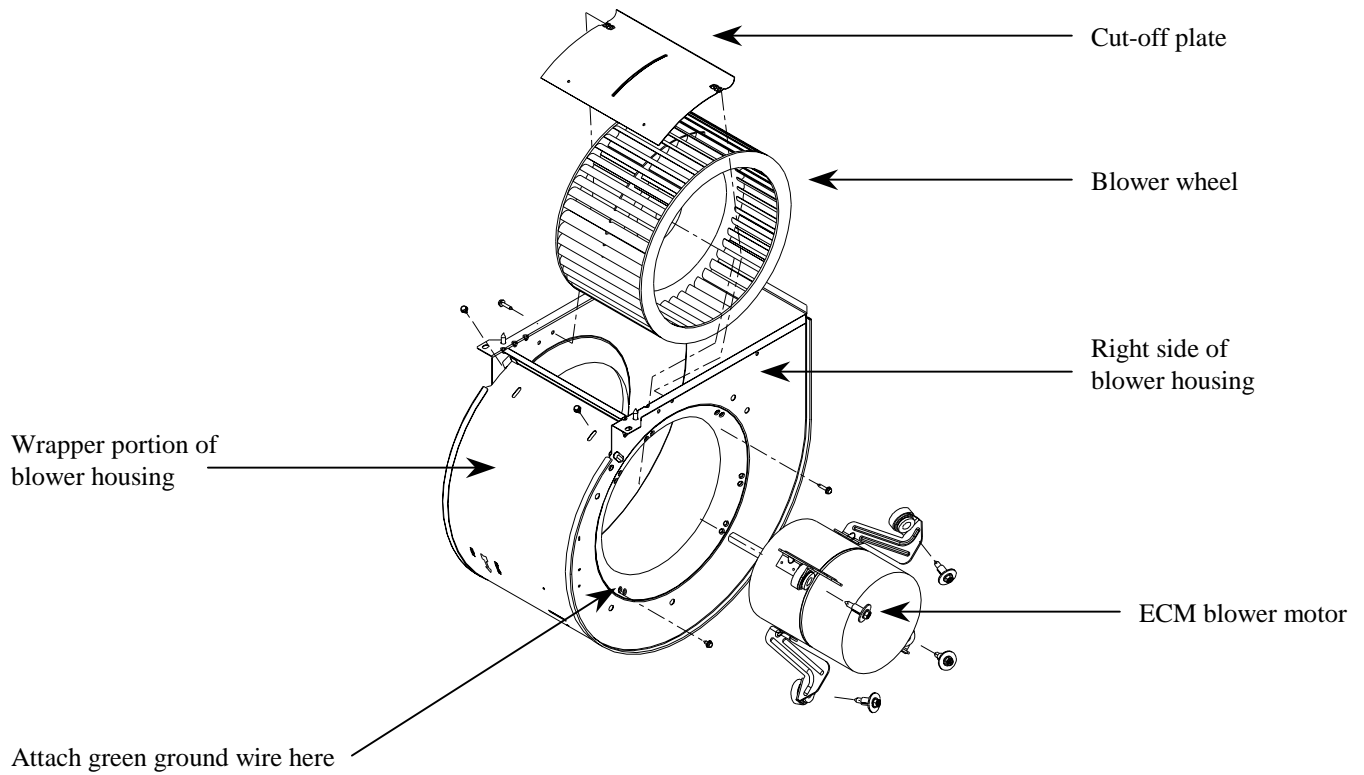

Fig. 2-Expanded View of ECM Blower Assembly



Manufacturer reserves the right to discontinue, or change at any time, specifications or designs without notice and without incurring obligations.