

BS2 GAS-FIRED STEAM BOILER

PRODUCT DATA



Fig. 1 – Model BS2

A12465

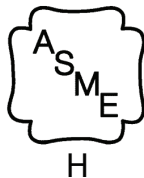

Use of the AHRI Certified TM Mark indicates a manufacturer's participation in the program. For verification of certification for individual products, go to www.ahridirectory.org.

A200078

This Model BS2 Gas-Fired Steam Boiler provides fast heat quietly and economically to assure the finest in hydronic heating.

This boiler provides quality design in a small, compact unit easily installed in a basement, garage, or utility room. It can be installed on a combustible floor when an optional combustible floor base is used.

The BS2 boiler is CSA certified for use with natural gas and is field convertible for use with propane gas when a factory-authorized conversion kit is used.

Features

Range of Capacities

These boilers are available in sizes 75,000 through 299,000 BTUH.

Completely Packaged

Each boiler is completely assembled, including all controls (except room thermostat). All necessary wiring is factory installed. The boiler is ready for gas, water, room thermostat, and electrical connections as shipped.

Thermal-Pin, Cast-Iron Sections

These sections speed heat transfer from the flue gases to the boiler water with faster thermostat response, providing greater comfort and economy. Maximum heat is produced at a lower level on the thermal-pin sections, leading to peak efficiency. Steel push nipples are used between each section to provide a water-tight seal.

Integral Draft

These boilers incorporate an integral draft system to simplify installation. No external draft diverter is needed.

Titanium Composite Burners

Provide quiet operation, corrosion resistance and improved combustion efficiency. Propane convertible with accessory kit.

Controls

An automatic gas valve and intermittent pilot provide quiet dependable operation of the burners. Factory-supplied safety components assure protection against overheating, pressure build-up and low-water operation.

Insulated Casing

The casing is fully insulated with fiberglass for maximum operating efficiency and economy.

Automatic Vent Damper

The BS2 boiler is CSA design certified for use with a factory-supplied automatic vent damper. This boiler is Category 1 for venting purposes.

Sections Tested

Each section is hydrostatically tested to 50 psig. Individual sections are tested to 125 psig at factory. Assembled sections are tested to 75 psig at the factory. Maximum allowable working pressure is 50 psig. The maximum allowable pressure is 15 psig for steam boilers.

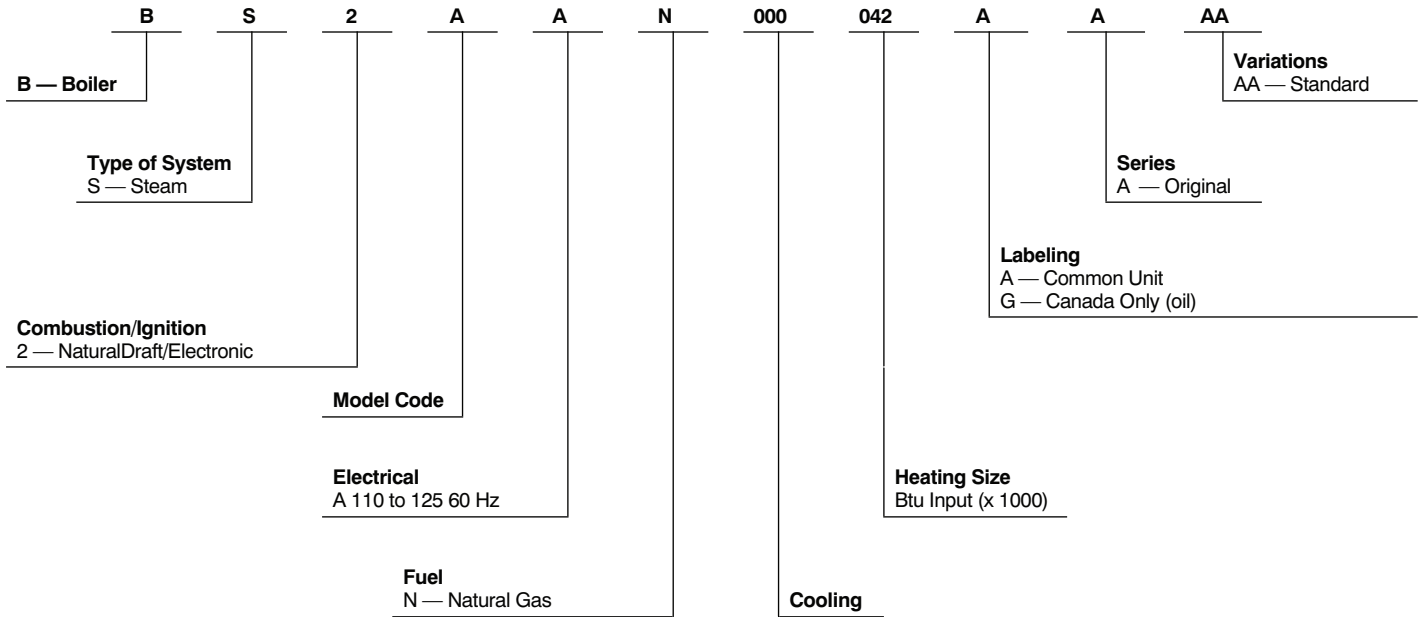

Fig. 2 – Model Number Nomenclature

A12449

Table 1 – Boiler Accessories

DESCRIPTION	PART NUMBER
Combustible Floor Base (2 thru 6 section models)	KBASB0301DNK
Combustible Floor Base (6 thru 7 section models)	KBAMB0401DNK
Gas Conversion Kit Natural-to-Propane (3 section, BS-075)	KBANP0301DNK
Gas Conversion Kit Natural-to-Propane (4 section, BS-112)	KBANP0401DNK
Gas Conversion Kit Natural-to-Propane (5 section, BS-150)	KBANP0501DNK
Gas Conversion Kit Natural-to-Propane (6 section, BS-187)	KBANP0601DNK
Gas Conversion Kit Natural-to-Propane (7 section, BS-225)	KBANP0701DNK
Gas Conversion Kit Natural-to-Propane (8 section, BS-262)	KBANP0801DNK
Gas Conversion Kit Natural-to-Propane (9 section, BS-299)	KBANP0901DNK
Gas Conversion Kit Propane-to-Natural (3 section, BS-075)	KBAPN0301DNK
Gas Conversion Kit Propane-to-Natural (4 section, BS-112)	KBAPN0401DNK
Gas Conversion Kit Propane-to-Natural (5 section, BS-150)	KBAPN0501DNK
Gas Conversion Kit Propane-to-Natural (6 section, BS-187)	KBAPN0601DNK
Gas Conversion Kit Propane-to-Natural (7 section, BS-225)	KBAPN0701DNK
Gas Conversion Kit Propane-to-Natural (8 section, BS-262)	KBAPN0801DNK
Gas Conversion Kit Propane-to-Natural (9 section, BS-299)	KBAPN0901DNK

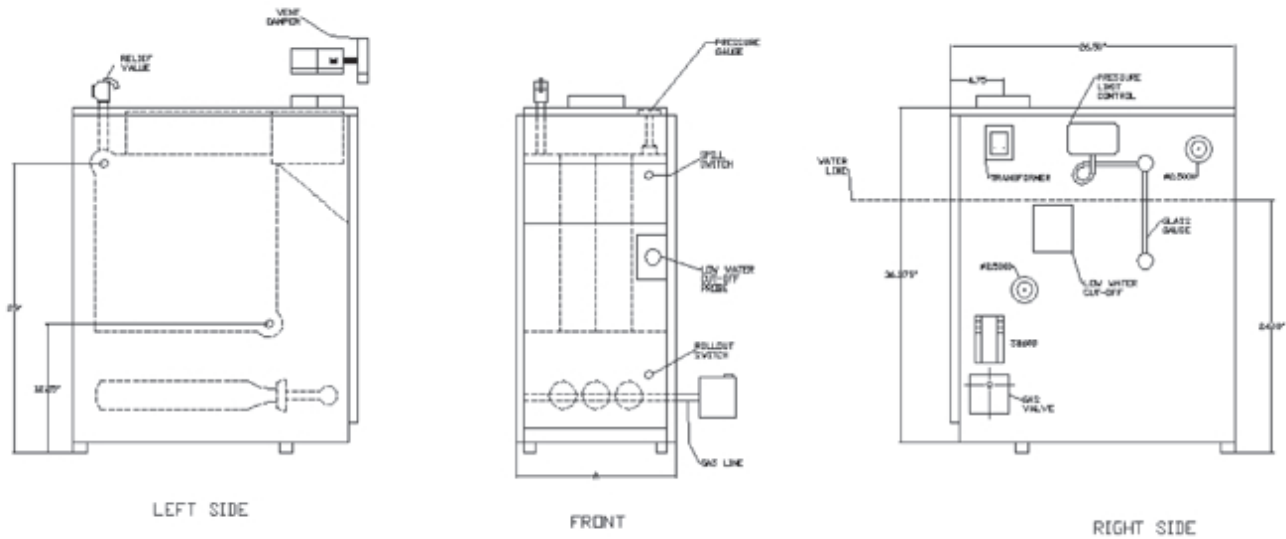

Fig. 3 – Fig. 2 - Dimensions

A12466

Table 2 – Clearances - in. (mm)

PART OF BOILER	CLEARANCE
Right Side	3 (76 mm)*
Left Side (Control Side)	9 (229 mm)
Top	18 (457 mm)
Back	8 (203 mm)
Front	18 (457 mm)*

*Service clearance requirement 24 in. (610 mm); Front alcove clearance 18 in. (457 mm).

Table 3 – Ratings and Capacities*

MODEL	GAS TYPE	NUMBER OF SECTIONS	MAX INPUT (BTUH)	HEATING CAPACITY (BTUH)	NET RATINGS		AFUE (WITH DAMPER)	APPROXIMATE SHIP WEIGHT LB.
					BTUH	SQ. FEET		
BS2AAN075	Natural	3	75,000	62,000	32,000	196	82.7	291
BS2AAN112	Natural	4	112,500	91,000	50,000	283	82.0	358
BS2AAN150	Natural	5	150,000	122,000	69,000	383	82.0	445
BS2AAN187	Natural	6	187,500	153,000	85,000	479	82.0	504
BS2AAN225	Natural	7	225,000	183,000	103,000	575	82.0	584
BS2AAN262	Natural	8	262,500	214,000	122,000	671	82.0	651
BS2AAN299	Natural	9	299,000	245,000	139,000	767	82.0	729

*Gas input ratings are for elevations up to 2000 ft. (610 M)

Table 4 – Specifications

UNIT SIZE	075	112	150	187	225	262	299
General Data							
Sections -Fine Grain Cast Iron	3	4	5	6	7	8	9
Burners-Stainless/Titanium Alloy	2	3	4	5	6	7	8
Burners- Orifice Drill Size (Natural)	34						
Gas Controls - Intermittent Pilot							
Gas Valve	Honeywell						
Inlet Size	1/2-in.	1/2-in.	1/2-in.	1/2-in.	1/2-in.	3/4-in.	3/4-in.
Pilot Assembly	Honeywell						
Spark Generator	Honeywell/UTEC						
Controls							
Low-Water cutoff	McDonnell Miller						
Pressuretrol (PSIG)	0 to 15						
Pressure Relief Valve (Setting / Capacity)	15 PSIG / 400 Lb. / Hr.						
Drain Cock (In.)	3/4						
Vent Damper*	5	6	7				

Table 5 – Electrical Data

ALL MODELS	
Voltage—Hertz—Phase	115 — 60 — 1
Minimum Branch Circuit Wire Size (AWG)	14
Maximum Fuse Size (Amps)	15
Control Circuit Power Available	40va—@ 24v